

HORIZONTAL RIBBON MIXER

Versatility

The APEC horizontal ribbon mixer has been installed world-wide in a variety of applications including animal feed, pet food, powdered drink mix, polyester resin, vitamin premixes, and mineral premixes.

Heavy Duty Construction

- The APEC horizontal ribbon mixers use a double ribbon agitator mounted with solid spokes to a solid center shaft. Shaft sizes range from 2-1/4" to 6" in diameter.
- The shaft mount reducer eliminates the chain and sprocket arrangements found on other mixers and simplifies maintenance. Drive sizes range from 3 to 60 hp.
- All mixers are constructed with a 3/16" or 1/4" thick tub and 1/4" or 3/8" end plates
- All mixers use ball bearing flange and spherical roller bearings to support the main shaft

Fast Cycle Times

Our design provides complete and gentle blending of ingredients.

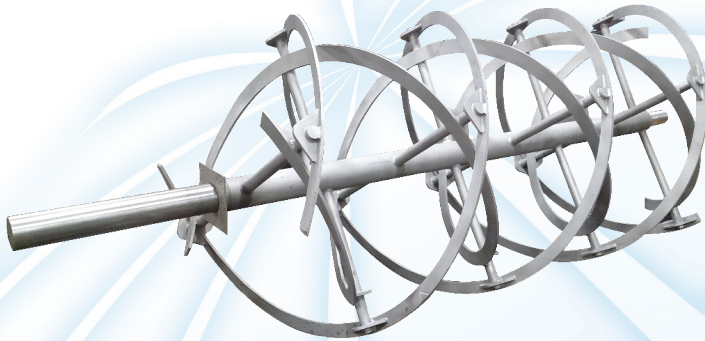

HORIZONTAL RIBBON MIXER SPECIFICATIONS

Mixer Sizes, Capacities (Swept Volume) and HP's

150 kg - 16.5 cu. ft. - 3 hp
250 kg - 28 cu. ft. - 5 hp
500 kg - 55 cu. ft. - 10 hp
1 MT - 77 cu. ft. - 20 hp
1.5 MT - 127 cu. ft. - 25 hp
2 MT - 159 cu. ft. - 30 hp
3 MT - 223 cu. ft. - 40 hp
4 MT - 294 cu. ft. - 50 hp
5 MT - 368 cu. ft. - 60 hp

Surge Capacities

150 kg - 20 cu. ft.
250 kg - 35 cu. ft.
500 kg - 60 cu. ft.
1 MT - 85 cu. ft.
1.5 MT - 135 cu. ft.
2 MT - 165 cu. ft.
3 MT - 230 cu. ft.
4 MT - 310 cu. ft.
5 MT - 380 cu. ft.

Available Options

- Mild Or Stainless Steel Discharge Surge
- 50 Hz Motors
- Explosion Proof Motors
- Mild and Stainless Steel Liquid Sparger Bar
- Load Cell Weighing Assemblies
- Surge Hopper with Low Level Detection
- Discharge Conveyor

Available Discharges

- Full Length Drop Bottom (Pneumatically Actuated)
- Standard Pneumatic End Slide Gate
- Optional Center Pneumatic Slide Gate

Available Finishes

- Standard weld finish is to CEMA II standards
- Standard factory paint finish is primecoat with finish coat of industrial enamel. APEC will match any customer paint specification provided.
- Stainless steel food grade finish available



PROCESSING THE INGREDIENTS FOR YOUR SUCCESS

HORIZONTAL RIBBON MIXER SPECIFICATIONS

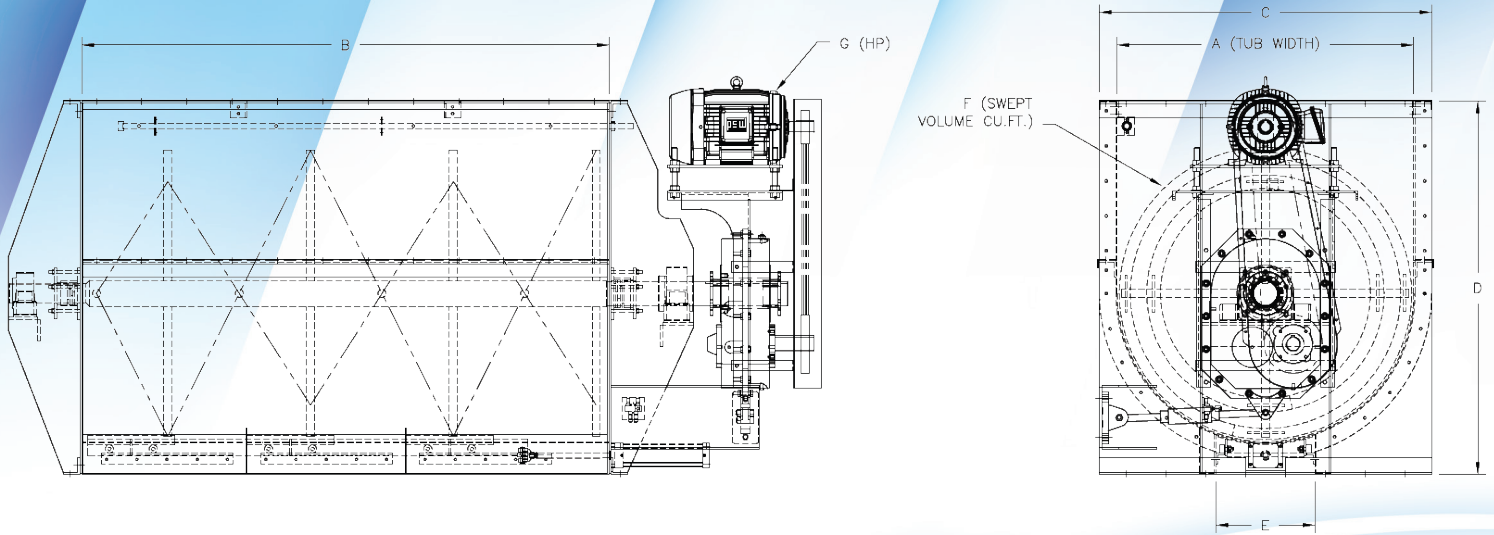

DIMENSIONS AND SHIPPING WEIGHT

Size	A	B	C	D	E	F	G	Weight
150 KG (mm)	26.00 660.40	54.00 1371.60	30.38 771.65	40.00 1016.00	13.00 330.20	16.50	3	1600
250 KG (mm)	32.00 812.80	60.00 1524.00	36.38 924.05	46.00 1168.40	15.00 381.00	28.00	5	2100
500 KG (mm)	38.00 965.20	84.00 2133.60	42.38 1076.45	48.00 1219.20	15.00 381.00	55.00	10	2400
1 MT (mm)	42.00 1066.80	96.00 2438.40	48.50 1231.90	56.00 1422.40	16.00 406.40	77.00	20	4050
1.5 MT (mm)	54.00 1371.60	96.00 2438.40	60.50 1536.70	68.00 1727.20	18.00 457.20	127.00	25	5000
2 MT (mm)	54.00 1371.60	120.00 3048.00	60.50 1536.70	68.00 1727.20	18.00 457.20	159.00	30	6500
3 MT (mm)	64.00 1625.60	120.00 3048.00	70.50 1790.70	80.00 2032.00	20.00 508.00	223.00	40	8800
4 MT (mm)	67.00 1701.80	144.00 3657.60	73.50 1866.90	84.00 2133.60	22.00 558.80	294.00	50	11000
5 MT (mm)	75.00 1905.00	144.00 3657.60	81.50 2070.10	90.00 2286.00	24.00 609.60	368.00	60	13000

SINGLE SOURCE PROCESSING SOLUTIONS FOR:

Dry and Liquid Coating | Mixing | Weighing
Batching | Blending | Material Handling



APEC

Automated Process Equipment Corporation

1201 North Fourth Avenue
Lake Odessa, MI 48849 USA
Ph: +1 (616) 374-1000
Fax: +1 (616) 374-1010
www.apecusa.com



APECHZLMIXER6/2019